

# Thesis Proposal

## *University of Virginia's College at Wise New Library*



*Image Courtesy of Cannon Design*

Macenzie Ceglar  
Structural Option  
Advisor: Heather Sustersic  
28 February 3014

## Executive Summary

The New Library at the University of Virginia's College at Wise, is 6 stories, 102 feet tall, 68,000 SF, and is located in Wise, Virginia. The existing structural system is composite steel with composite metal deck. The framing system consists of steel wide flange members, and the lateral system consists of ordinary reinforced concrete shear walls. The building is also being integrated into a 60 foot hillside and utilizes a temporary retaining wall system and foundation walls that are designed to take the full lateral soil forces in the future.

The existing structural system of the New Library is adequate to meet both strength and serviceability requirements. Therefore, a scenario has been proposed in which the University would like to investigate the option of a concrete system instead of the current steel system. The University would also like to investigate the option of a post-tensioned floor system.

A solution to this scenario will be provided through the proposed structural depth in which the building's structural system is redesigned using a mild-steel reinforced concrete flat slab with drop panels and analyzed using RAM Concept. The existing lateral system will be integrated with the concrete floor system and analyzed using ETABS. Concrete columns will be designed using the existing layout per the request of the architect in order to limit the redesigns impact on the building's interior layout.

In order to determine the feasibility of changing the building's structural system to concrete, the impact on the cost and construction schedule will be compared to that of the current steel system as the proposed construction breadth.

Due to the large retained soil depth at the building foundation walls, the proposed mechanical breadth will investigate the fluid at the base of the walls to determine an adequate drainage system.

In addition, MAE coursework will be incorporated into the proposed redesign through the use of computer modeling using both ETABS and RAM Concept (AE530).

## Purpose and Scope

The purpose of this proposal is to present an overview of the work that will be completed during spring semester 2014. Included is a proposed problem scenario and structural depth involving the redesign of the New Library's structural system using reinforced concrete. Two individual breadth studies, along with proposed MAE course work are also presented. The first breadth will involve an analysis of the impact of this redesign on the cost and construction schedule. The second breadth will involve and an investigation of the drainage system at the base of the foundation wall and a design of a waterproofing system for both the foundation walls and basement slab. The MAE course work will include computer modeling using ETABS and RAM Concept. A detailed task outline and work schedule is also provided.

# Table of Contents

Executive Summary.....	2
Purpose and Scope.....	2
Table of Contents.....	3
General Description of Building.....	4
Structural Overview of Existing System.....	5
Brief Description of the Existing Structural System.....	5
Building Materials.....	5
Foundation System.....	6
Floor System.....	10
Framing System.....	11
Roof System.....	12
Lateral System.....	14
Design Codes and Standards.....	15
Design Loads.....	16
National Code for Live Loads and Lateral Loadings.....	16
Gravity Loads.....	16
Live Loads.....	16
Dead Loads.....	16
Snow Loads.....	17
Lateral Loads.....	17
Wind Loads.....	17
Seismic Loads.....	17
Lateral Soil Loads.....	17
Problem Statement.....	18
Proposed Solution.....	18
Breadth Topics.....	19
Construction Breadth.....	19
Mechanical Breadth.....	19
MAE Requirement.....	19
Tasks and Tools.....	20
Schedule.....	22
Conclusion.....	23

# General Description of Building

The New Library at the University of Virginia’s College at Wise will be located directly between the existing lower and upper parts of the campus, as seen in Figure 1. The new 68,000 ft<sup>2</sup> building will be 6 stories tall and will cost approximately \$43 million.

Currently, there is a steep 60 foot hill dividing the UVA Wise campus. This had a large impact on the building’s overall design. The New Library will be integrated into the hillside, shown in Figures 2 and 3, and will serve as a significant physical and architectural link between the two parts of campus. A long winding staircase is built into the existing hillside, and provides limited access for students. Students will be able to access the building from the first, second, third, fourth, and fifth levels and a 24 hour access zone will allow students to travel across campus more easily and safely after normal operating hours.

Structurally, the design includes a temporary retaining wall system and foundation walls which extend up to 68 feet below grade on the eastern corner of the building.

The University Architect wanted the New Library to bring a sense of cohesion to the existing buildings on campus. The design team was required to create a visual effect in which it would appear as if the surrounding buildings had been designed based on the New Library, thus creating an architectural link between the new building and the existing buildings. Architectural materials such as brick, stone, and cast stone, were chosen for the library’s façade, as these are common to the existing buildings on campus. Along with numerous books and reference materials, the library will offer several other amenities to students including study rooms, conference rooms, smart workstations, and a café.



Figure1: Site Location (Courtesy of Cannon Design)



Figure2: New Library (Courtesy of Cannon Design)

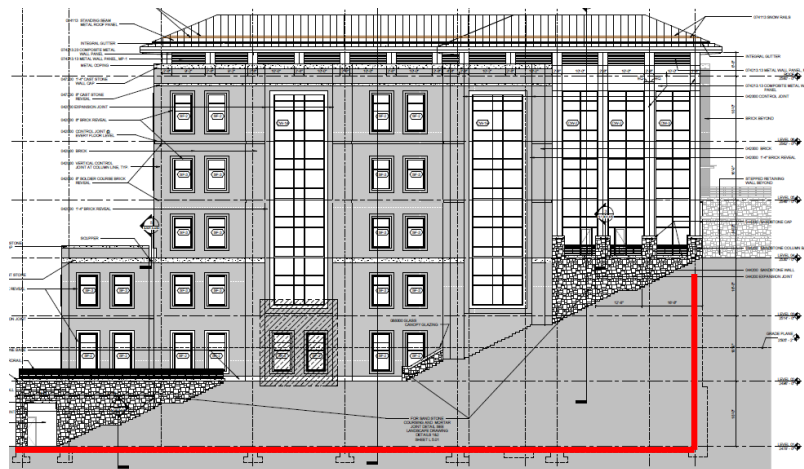

Figure 3: South Elevation Showing Building’s Depth into Hillside(Sheet A-3.01)

# Structural Overview of Existing System

## Brief Description of the Existing Structural System

The New Library at the University of Virginia’s College at Wise sits on a foundation system that consists of column piers, spread and strip footings, and foundation walls. Each floor of the 6 story building is framed using a composite system consisting of composite steel wide flange members and composite decking. Concrete shear walls make up the building’s lateral system, along with several foundation walls that aid in resisting lateral soil loads. The upper roof system is comprised of pre-engineered cold formed metal trusses and a separate lateral system consisting of cold formed shear walls. The following section explains these components in more detail.

## Building Materials

Structural building materials used in the New Library’s design, along with their specifications, are listed below in Figures 4 and 5.

Structural Steel		
Member	Grade	Fy (ksi)
Wide Flange Shapes and WT Sections	ASTM A992	50
Channels and Angles	ASTM A36	36
Pipe	ASTM A53, Grade B	30
Hollow Structural Sections	ASTM A500, Grade B	46
Base Plates	ASTM A36	36
All Other Steel Members	ASTM A36	36
High Strength Bolts, Nuts, and Washers	ASTM A-325 or A4-490 (Min. ¾" φ)	

**Figure 4: Structural Steel Materials Specifications**

Concrete and Reinforcing		
Use	Strength (psi)	Weight (pcf)
Footings	3000	150
Building Foundation Walls	5000	150
Slabs-On-Grade	3000	150
Slabs-On-Steel Deck	3000	150
All Other Concrete	4000	150
Use	Grade	
Typical Bars	ASTM A-615, Grade 60	
Welded Bars	ASTM A-706, Grade 60	
Welded Wire Fabric	ASTM A-185	

**Figure 5: Concrete and Reinforcing Specifications**



## Foundation System

S&ME, Inc. performed a geotechnical exploration of the proposed site for the New Library in January 2012. They recommended that the main library structure be supported on spread foundations bearing on bedrock with 8 kip per square foot (ksf) allowable bearing pressure. Due to the high bearing pressure, there was no need for soil improvements. It was also determined that the retaining walls need to be capable of resisting an equivalent fluid pressure of 47 pounds per cubic foot (pcf). See the lateral soil loads section for more details.

The final design for the building's foundation followed the recommendations provided in the geotechnical report. The New Library will be supported on a shallow foundation which will consist of individual spread footings and continuous strip footings, both of which will bear on bedrock.

The individual spread footings are located under the steel columns. At interior columns, the spread footings are located directly at the base of the column (see Figure 6). At exterior columns the spread footings are located at the base of the column piers (see Figure 7). In both of these cases, the connection is most likely pinned due to the use of the minimum number of required anchor bolts (4), and the fact that no moment frames are used in the structure.

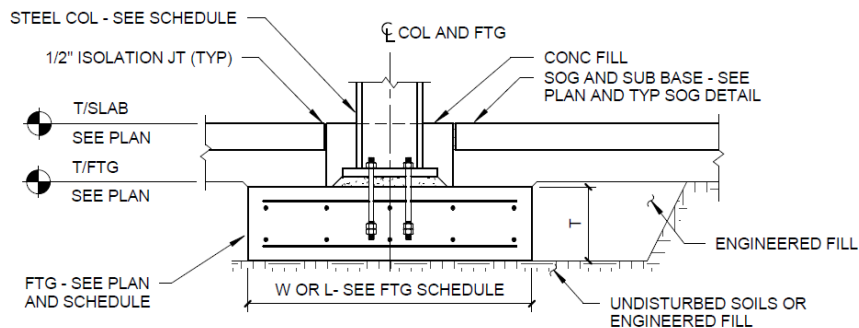

**Figure 6: Typical Column Footing without Pier (Sheet S-3.01, Detail 2)**

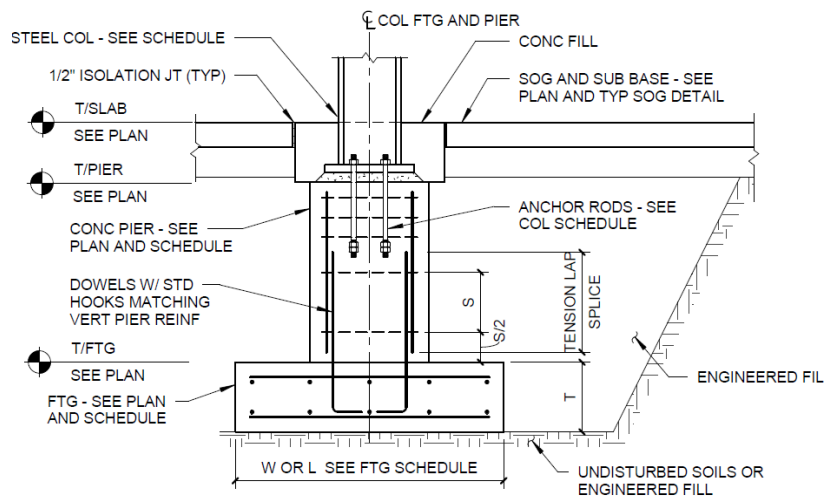

**Figure 7: Typical Column Footing with Pier (S-3.01, Detail 1)**

Continuous strip footings are located under the perimeter foundations walls. Many of the footings are stepped in order to limit the amount of excavation required.

One of the biggest challenges with the project was designing a way to resist the lateral soil forces on the building's structure. After discussing several options, the team chose to use a temporary leave-in-place soil retention system (which includes the use of soil nails and shotcrete covering). This system was determined to be the most cost effective and efficient solution. The temporary system allows the soil to be excavated down to the bearing grade and the shotcrete then doubles as one side of the formwork for the foundation walls, thus decreasing the cost of formwork for the project.

It is expected that the rock anchors will deteriorate over time. Thus, the foundation walls are redesigned to resist the full soil load once the superstructure is complete. This was done by designing the foundation walls with a fixed-base condition, providing sufficient rebar to resist flexure, eccentric footings, and lateral support at upper floor levels. The foundation wall and this design concept can be seen in Figures 8 and 9.

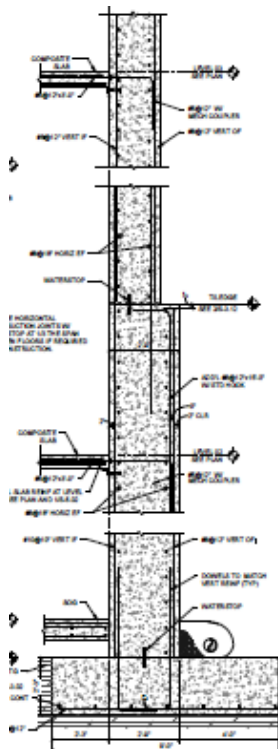

Figure 8: Foundation Wall(S-3.11, Detail 1)

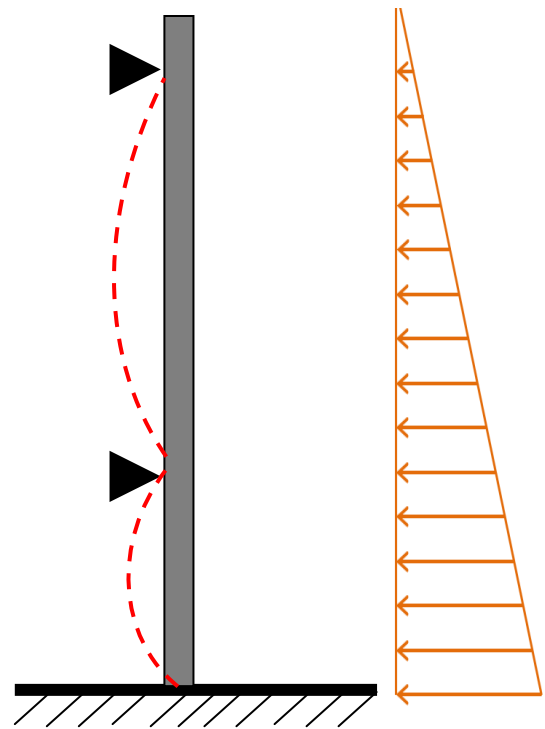
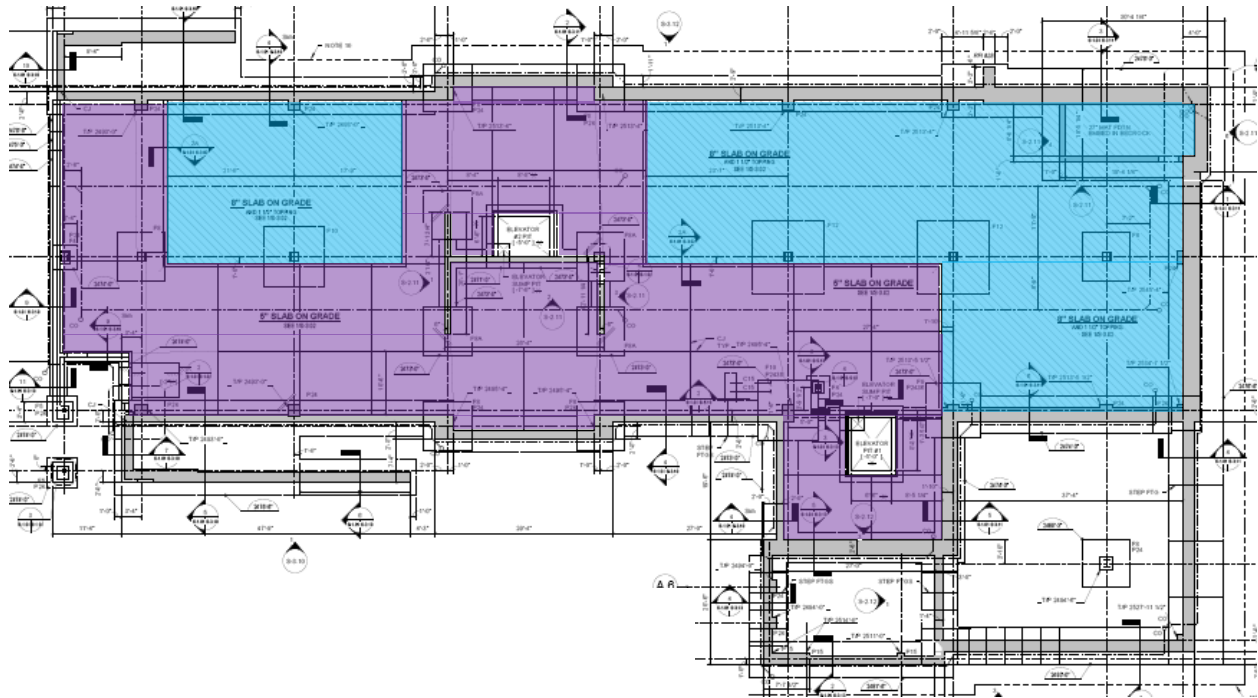

Figure 9: Foundation Wall with Design Concepts

### Slab Thicknesses

Two different slab-on-grade thicknesses are used in the building. A 5" slab-on-grade, reinforced with 6x6-W2.9xW2.9 welded-wire-fabric, is located at Levels 1 and 2. On level 1, these slabs are located in the 24-hour access zone, which is an area of moderate student traffic. On Level 2, there is also a small section in the south corner of the building that is on grade and utilizes a 5" S.O.G. An 8" slab-on-grade, reinforced with #5@18" each-way on both the top and the bottom is located on Level 1. It is supporting areas of high density storage where specialty compact shelving will be located. Figure 10 and 11 show the extents of each slab thickness on Levels 1 and 2.



**Figure 10: Level 1 Slab-On-Grade Thicknesses (S-1.01)**

	5"
	8"



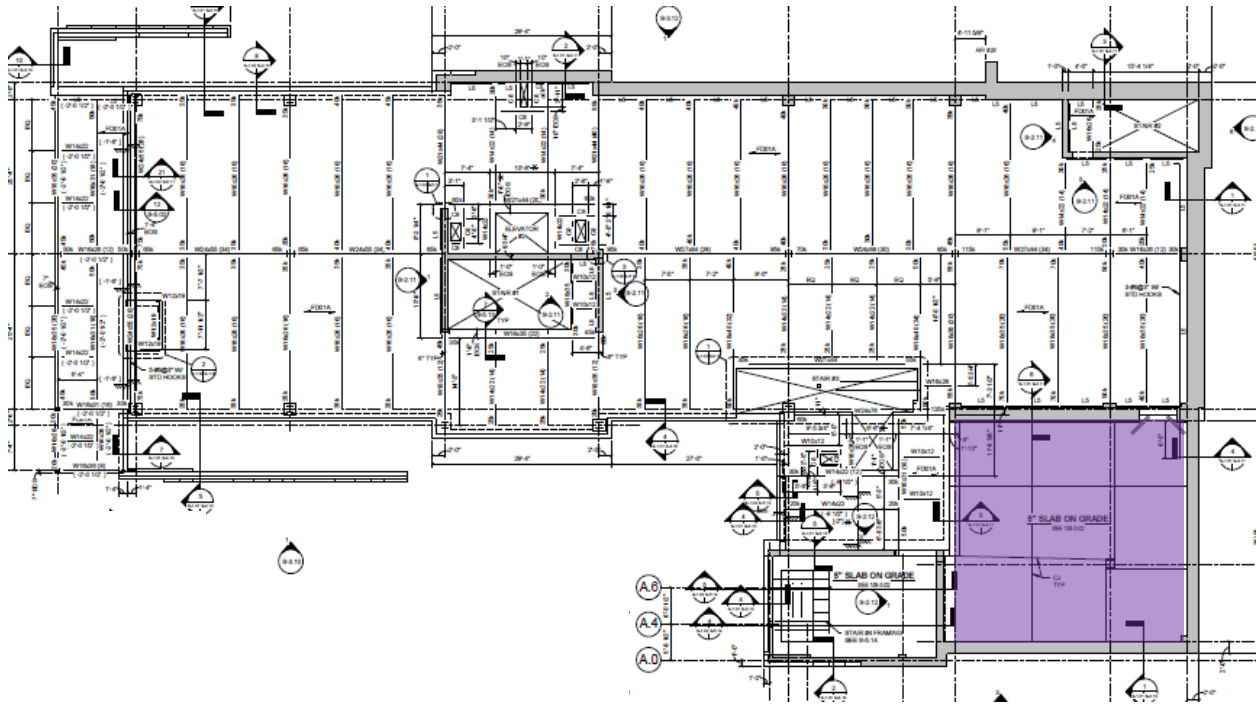

**Figure 11: Level 2 Slab-On-Grade Thicknesses (S-1.02)**

5"

## Floor System

The New Library’s floor system is a composite steel system comprised of 4 ½” normal weight concrete reinforced with 6x6-W2.9xW2.9 welded-wire-fabric on 2” 18 gage steel deck (6 ½” total thickness). The 4 ½” topping provides the required 2 hour fire rating without the additional cost of spray-on fire proofing. The deck typically runs perpendicular to wide flange steel members, and in cases where the deck runs parallel to the members, #4 x 4’-0” rebar is placed at 18” on center to decrease cracking due to tensile forces in the concrete slab. Composite action is achieved by transfer of the load from the slab to the members by ¾” diameter x 3 ½” long shear studs.

### Typical Bay: Floor

Multiple sized bays are used in the New Library. The typical beam span is 25’-4” and typical bay sizes range from 25’-4” to 31’-0”. Typical members used to frame Level 2 up through Level 6 are primarily W16x26 beams. Smaller beams, such as W14x22, are used in areas around the stairwells and larger beams, such as W18x35, are used in areas supporting general collections along with areas of high student traffic. Typical interior girders supporting these beams are W25x55 and spandrel girders vary in size depending on location. Figure 12 below shows a 27’-4” bay with W16x26 beams.

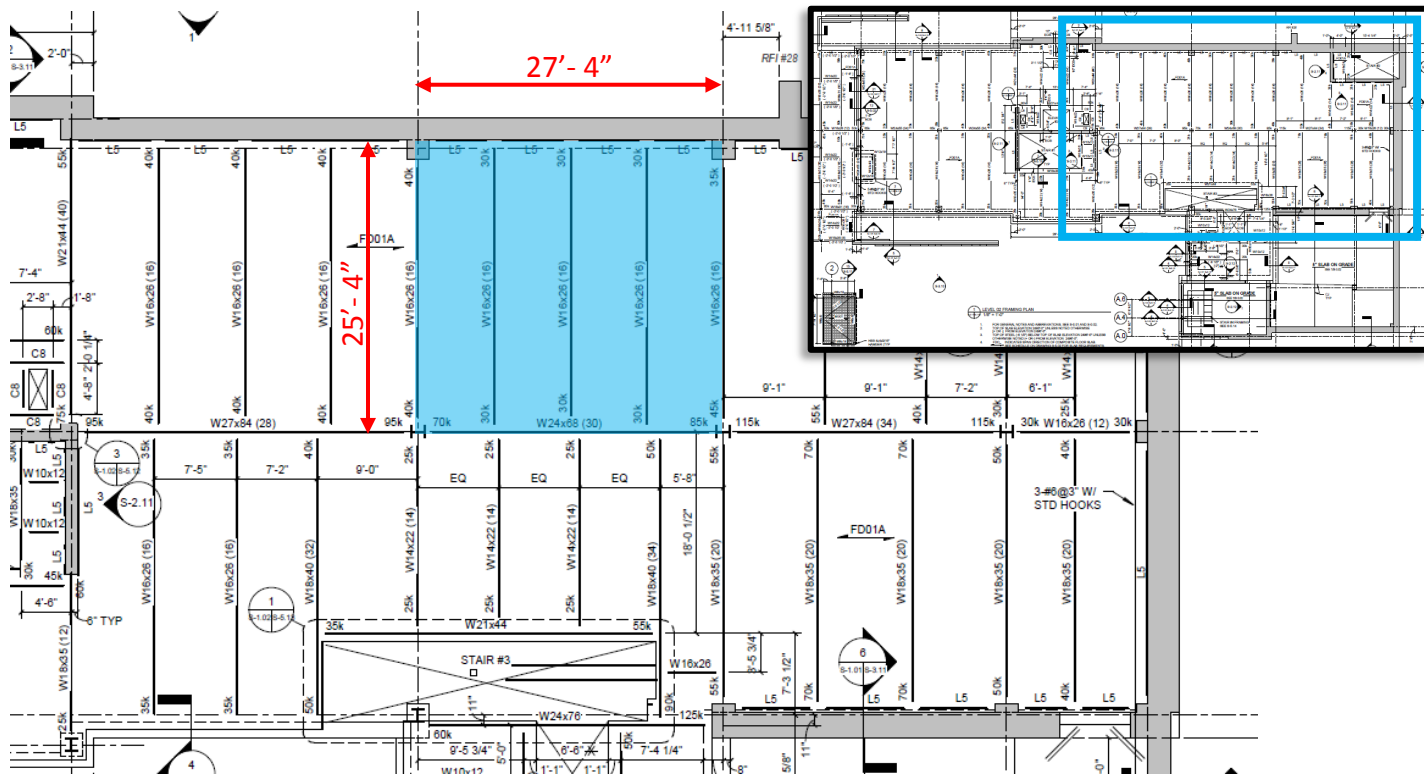

Figure 12: Level 2 Framing Plan Showing Typical Bay (Sheet S-1.02)

## Framing System

All of the main structural columns in the New Library are wide flange steel members. Other columns found in the building are hollow structural steel, which are used in vestibules and in entrance areas. Most of the columns have a 12" depth and vary in weight; with the majority ranging between W12x45 and W12x65. The largest columns in the building are W12x170 and they extend between Level 1 and Level 3. The need for these larger columns is due to the increased tributary area, as compared to typical bays, and larger design loads from general collections on all upper floors. Figure 13 shows the location of the W12x170 columns.

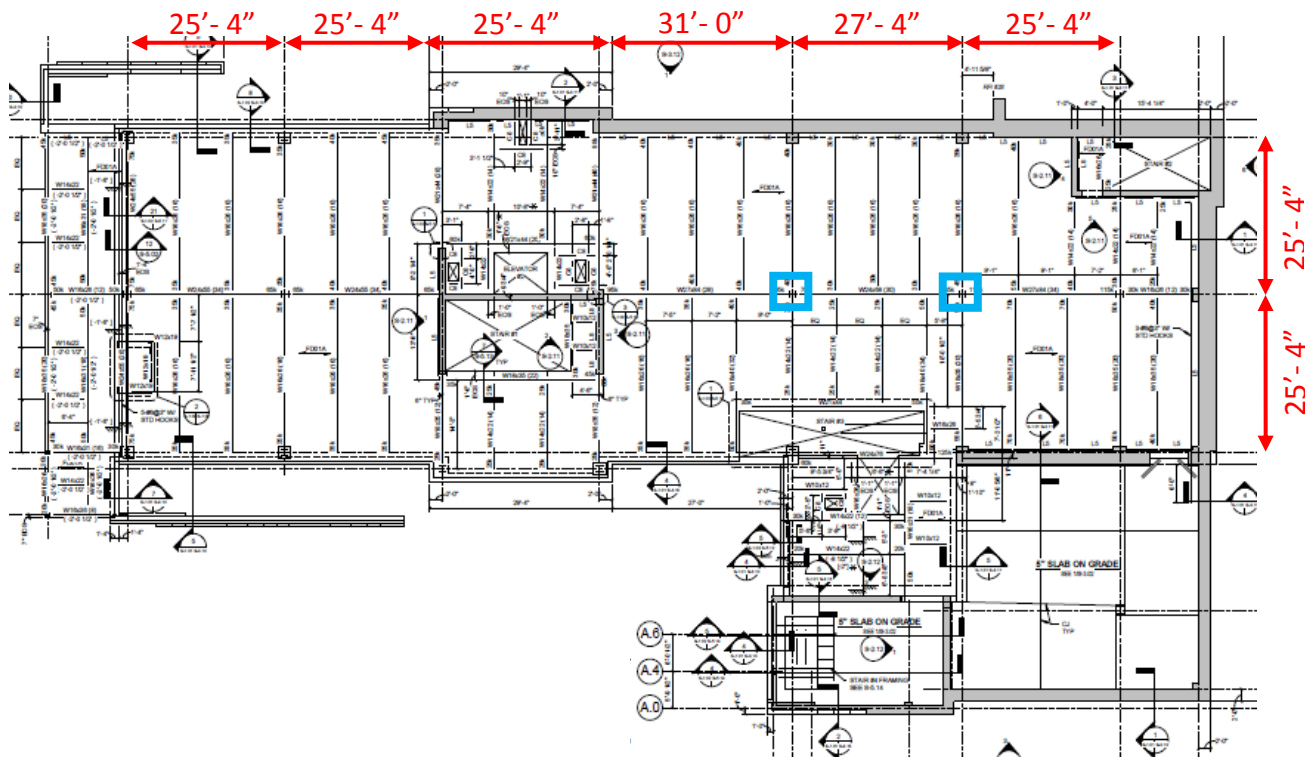

Figure 13: Level 2 Showing Location of W12x170 Columns (Sheet S-1.02)

## Roof System

Two separate roof systems were used to complete the New Library. A lower roof covers the majority of the building between column lines 3-9 and A-E and supports an air handling unit and a chiller (mechanical well area). The framing is composite wide flange steel beams and a 6 1/2" NWC slab. The upper roof is designed to mimic the existing campus buildings and also serves to conceal the building's air handling unit and chiller.

### Lower Roof

Bay sizes used in the lower roof framing of the New Library are the same as those used in the framing of the lower floors. The typical beam span is 25'-4" and typical bay sizes range from 25' 4" to 31'-0". Beams used to frame the lower roof are typically W18x35. This larger beam size is due to increased design loads based on the HVAC system. Figure 14 below shows a 27'-4" bay with W18x35 beams.

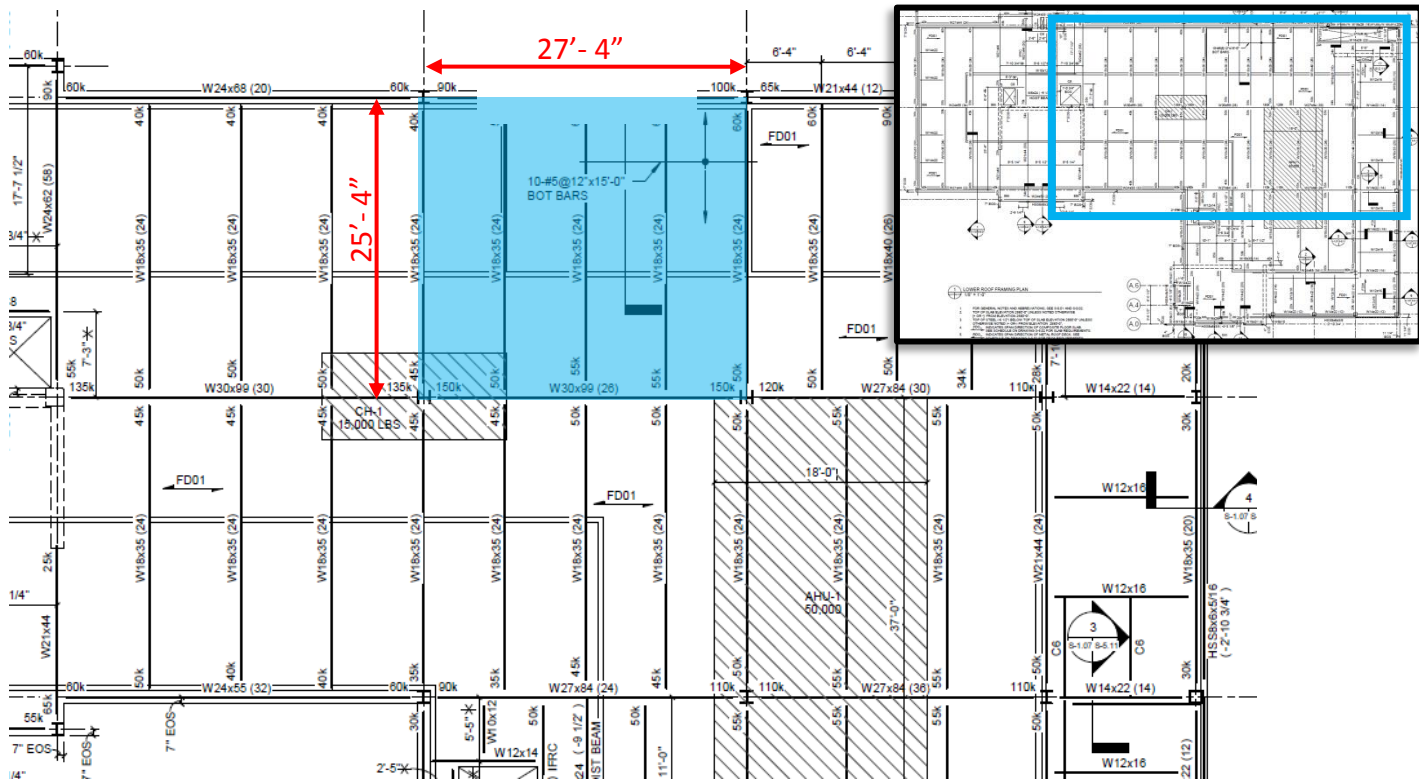
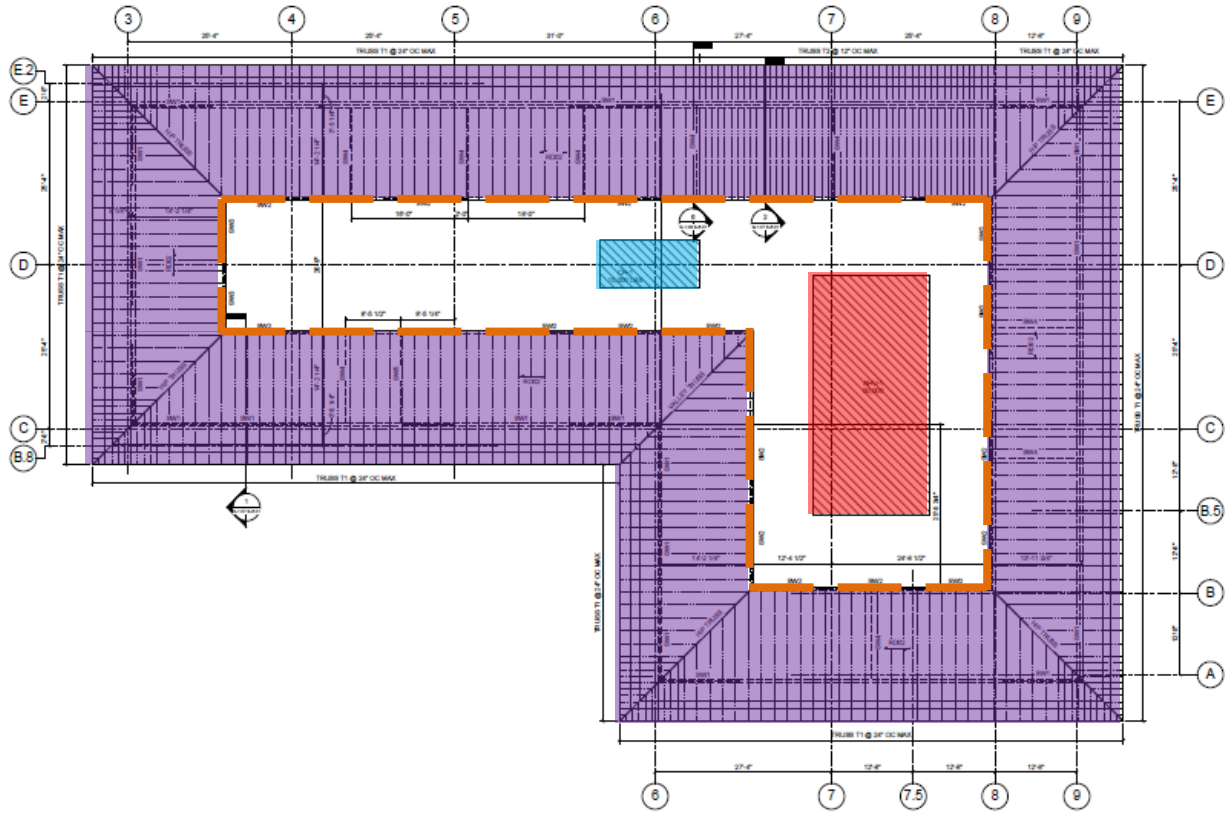

Figure 14: Lower Roof Framing Plan Showing Typical Bay (Sheet S-1.07)

### Upper Roof

The upper roof is a raised false mansard consisting of pre-engineered cold formed metal trusses and cold formed shear walls. This layout can be seen below in Figure 15. These trusses are triangular in shape and approximately 9'-7" tall, are covered by 1 1/2" type B roof deck, and sit on 6" load bearing CFMF studs. This can be seen below in Figure 16.



**Figure 15: Upper Roof Framing Plan Showing Pre-engineered Trusses (Sheet S-1.08)**

- Pre-engineered Light Gage Cold Formed Metal Trusses
- Mechanical Well Area
- Air Handling Unit
- Chiller

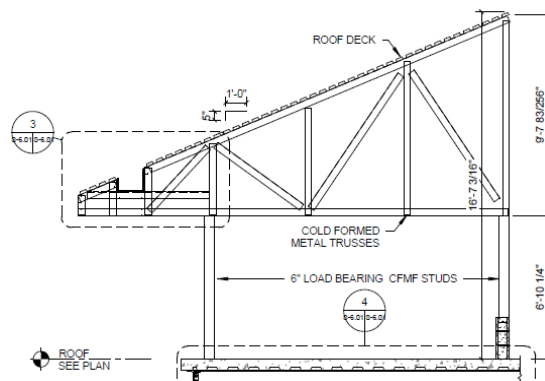

**Figure 16: Cold Formed Metal Truss (S-6.01)**

## Lateral System

The lateral force resisting system for the New Library consists of ordinary reinforced concrete shear walls. There are nine 12” thick shear walls of varying length and height that make up this system. Figure 17 shows the location of these shear walls and categorizes them based on their heights.

Each shear wall is reinforced with #5 rebar at a code maximum spacing of 18” each-way on each-face of the wall. This layout of reinforcing is typical with the exception of two walls that have condensed spacing in lower sections of the wall, especially in the horizontal direction. This condensed spacing is due to increased shear forces from soil loads.

Two of the walls located in the eastern corner of the building are introduced below grade as foundation walls. Levels 1 through 4 of this corner are located below grade at the location of the maximum retained soil. Once above-grade, soil loads no longer are the controlling load case and the walls are then designated as shear walls.

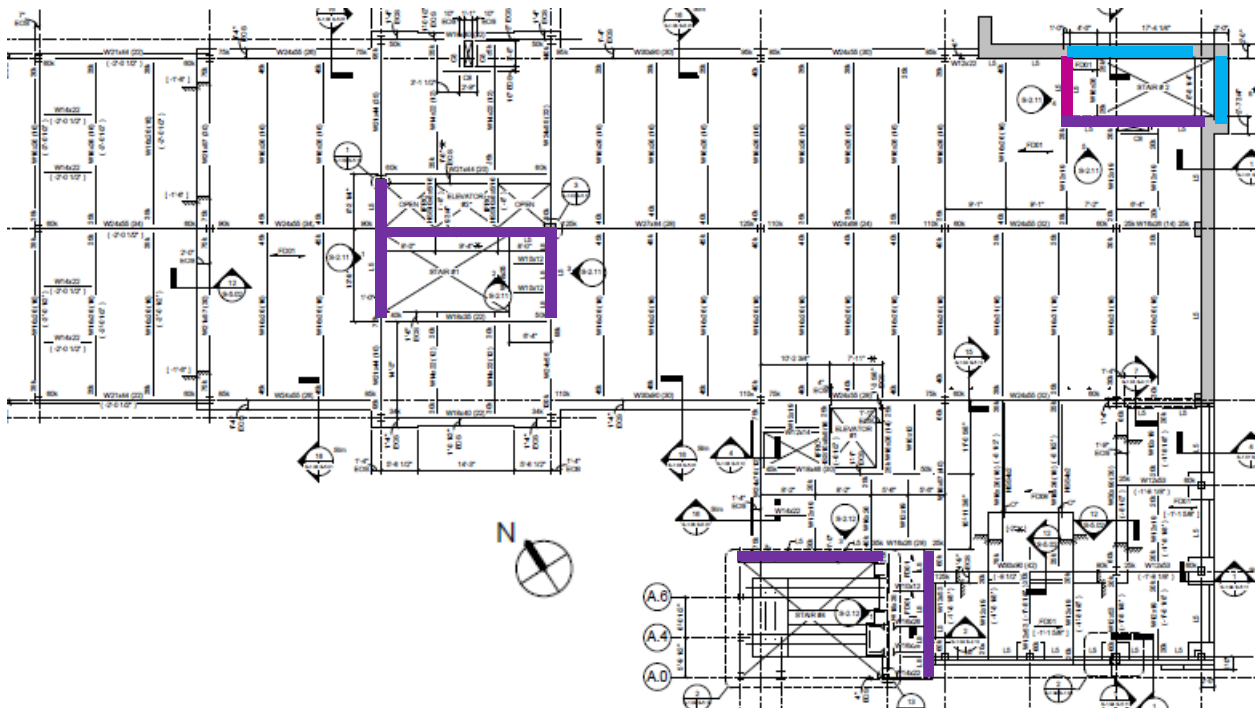

**Figure 17: Floor Framing Plan Showing Shear Wall Locations (S-1.04)**

- Shear Walls From Level 1 to Roof Level
- Shear Walls From Level 1 to Level 5
- Shear Walls From Level 5 to Roof Level



# Design Codes and Standards

Below is a list of the design codes and standards used in the structural design of the New Library at the University of Virginia's College at Wise:

- **International Code Council**
  - International Building Code 2009 (Chapters 2-35 Adopted by Virginia Uniform Statewide Building Code)
- **American Society of Civil Engineers**
  - ASCE 7-05: Minimum Design Loads for Buildings and Other Structures
- **American Concrete Institute**
  - ACI 318-08: Building Code Requirements for Structural Concrete
  - ACI 530-08: Building Code Requirements and Specifications for Masonry Structures
- **American Institute of Steel Construction**
  - AISC 360-05: Specifications for Structural Steel Buildings (Steel Construction Manual 13<sup>th</sup> Edition) - LRFD
- **University of Virginia Facilities Management and University Building Official**
  - Facility Design Guidelines

# Design Loads

The following section focuses on topics concerning the loads used in the structural design of the New Library. These topics include national codes used for live and lateral loadings, the determination of the design loads used, and the load paths for different loading conditions.

## National Code for Live Loads and Lateral Loadings

Load	National Code	Section
Live	ASCE 7-05 Chapter 6, and UVA Facility Design Guidelines	5
Lateral	ASCE 7-05 Chapter 12	8

*Figure 22: National Code Chapter and Section for Live and Lateral Load*

## Gravity Loads

### Live Loads

Design live load values are listed on sheet S-0.01 of the structural drawings. The majority of these loads were determined using Chapter 4 of ASCE7-05, with the exception of the design roof loads. The loads not found in ASCE 7-05 are listed in Figure 23 with an explanation of how they were determined.

Load	Determination of the Load
Roof area below sloped roof	The area below the sloped roof will most likely never see a live load, so the design team chose to simply provide a small allowance.
Roof mechanical area	The design team chose to blanket the roof with a live load instead of using the specific dead loads for the mechanical units. To determine a reasonable allowance the team used the largest PSF unit at the time and increased the load by 25%.
Minimum Roof Live Load	UVA Facility Design Guidelines specifies a minimum design roof live load.

*Figure 23: Live Loads Not Found in ASCE7-05*

### Dead Loads

Design dead loads are listed on sheet S-0.01 of the structural drawings. These loads were based on material weights and industry standards used at Cannon Design.

## Snow Loads

Design snow loads must follow the UVA facility Design Guidelines. These guidelines state that ground snow loads are to be determined by case studies and other Virginia Unified Statewide Building Code requirements. The USBC adopts chapters 2-35 of IBC 2009 which references ASCE 7-05.

## Lateral Loads

### Wind Loads

Design wind loads were determined using Section 6.5 of ASCE 7-05. Section 6.5, Method 2, which is the analytical procedure for determining design wind loads for buildings of all heights.

### Seismic Loads

Design seismic loads were determined using section 12.8 of ASCE 7-05. Section 12.8 prescribes the Equivalent Lateral Force Procedure for determining seismic design loads.

## Lateral Soil Loads

From the geotechnical report performed by S&ME, Inc. it was determined that the foundation walls should be designed for an at-rest equivalent fluid pressure of 47 pcf. The soil loads on the foundation walls are then dependent on the height of the wall. Figure 24 shows this distributed force on the foundation wall.

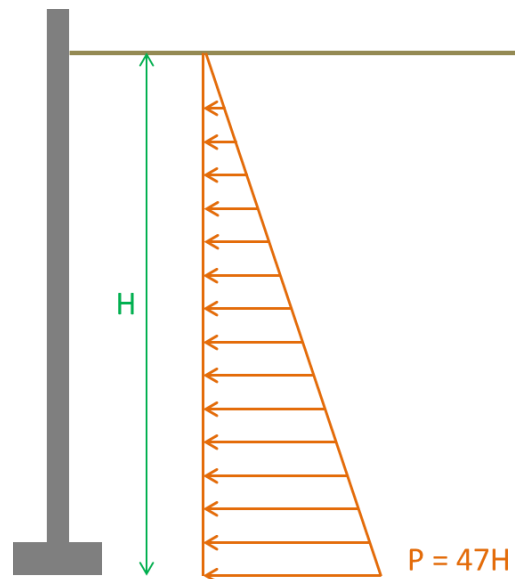

**Figure 24: Equivalent Lateral Fluid Pressure**

## Problem Statement

As previously discussed, the New Library utilizes a composite steel framing system, and the lateral system involves the use of ordinary reinforced concrete shear walls. Previous technical reports have shown that the existing gravity system and lateral system for the New Library are adequate to meet both strength and serviceability requirements.

Since no significant problems exist with the current steel structural system, a scenario has been created in which it is desired by the University to investigate the feasibility of a concrete framing system. As part of this investigation, the impact of the concrete system on the cost and construction schedule of the project should be compared to that of the existing steel system to allow the owner to make an informed decision. The architectural design of the New Library is based on the existing campus and surrounding buildings, so it is required that there is limited architectural impact with the system redesign.

## Proposed Solution

The new structural system has been chosen to be a mild-steel reinforced two-way concrete slab with drop panels. This system will be analyzed using RAM Concept, which is one of the most efficient tools for designing concrete floor systems. It has already been determined that the existing shear walls are the most efficient lateral system and will be integrated with the new concrete system. ETABS will then be used to analyze the existing shear walls under anticipated increased seismic loads due to the increase in building mass. Columns will also be redesigned in concrete and will follow the existing column layout in order to minimize impact to the interior layout of the New Library.

The decision to use a two-way slab as the primary re-design was based on several factors. In Technical Report 3, a two-way flat slab was found to be the least expensive of the alternative concrete systems that were studied. Two-way systems with drop panels help to reduce the amount of negative reinforcement required at the columns and have become an industry standard. The bay sizes of the New Library are of a moderate span, approximately 25 feet, and are relatively square, which is ideal for a two-way slab system.

The largest bay in the New Library spans 31 feet. It is recognized that excessive deflections in this bay will be an area of concern with the alternate system. To address this issue alternative drop panel sizes and shallow beams will be investigated.

There is also an interest to investigate the option of a post-tensioned system as a secondary re-design. A schematic design of the full floor system will be designed using RAM Concept and will be compared to the two-way concrete system in order to determine if a complete PT floor option would be a practical option.

# Breadth Topics

## Construction Breadth

A comparative cost analysis will be performed in which the cost of the existing composite steel system will be compared to that of the redesigned two-way concrete system. This cost analysis will include materials, erection/formwork, and labor. Cost information for the existing steel system will be provided by Cannon Design, while cost information for the redesigned concrete system will be determined using RS Means.

A schedule analysis will also be performed in which the impact of this system change on the critical path and construction schedule will also be considered. The construction schedule and the critical path required for the concrete system will be compared to that of the existing steel system, which will be provided by Cannon Design.

## Mechanical Breadth

Drainage at the base of the foundation/basement walls will be investigated. The location of the ground water levels in relation to the footings will be determined and the flow rate of the ground water and rain water will be calculated. It is assumed that a drainage system will be required. Thus, a drainage pipe and sump pump, if needed, will be sized based on the flow rate and code specifications.

Waterproofing for the foundation/basement walls and the effect of the water beneath the slab-on-grade will also be investigated.

## MAE Requirement

Graduate level work will be incorporated into the structural system redesign. This will be done through the use of computer modeling. Material covered in AE530, *Computer Modeling of Building Structures*, will be used extensively throughout the redesign. ETABS will be used in the analysis of the lateral system under ACSE7-10 wind and seismic loads and increased gravity loads due to the increased building weight. ETABS will be used to verify the shear walls for these increased loads. RAM Concept will be used in the design of the conventionally reinforced concrete slab and the post-tensioned concrete slab. This program will be learned through guided self-study for modeling of both conventionally reinforced concrete slabs and post-tensioned systems.

# Tasks and Tools

1. Winter Break Research
  - a. Gain experience using RAM Concept through self-directed learning
  - b. Obtain original construction schedule for the existing steel system
  
2. Design Concrete System
  - a. Design gravity system including two-way slab, drop panels, and columns
    - i. Calculate newloads considering increased dead load
    - ii. Design reinforced two-way slab
      1. Determine trial slab thickness and trial column sizes
      2. Use RAM Concept to analyze slab
      3. Investigate need for drop panels
      4. Determine required reinforcement
      5. Check deflections and adjust slab thickness, drop panel arrangement, and amount of reinforcement to account for excessive deflections in problem areas
    - iii. Design gravity columns and check using SP Column
  - b. Investigate the option of a post-tensioned system
    - i. Research the possibility of a PT system
    - ii. Calculate an approximat number of tendons
    - iii. Use RAM Concept to layout tendons and determine required amount based on stresses and deflections
  - c. Check lateral system
    - i. Adjust seismic loads for new building weight
    - ii. Modify Technical Report 4 ETABS model to include adjusted loads
    - iii. Analyze shear walls under increased seismic loads
  
3. Perform cost and schedule comparison of existing system and new system
  - a. Cost analysis
    - i. Determine cost of materials, formwork, and labor using RS Means
    - ii. Calculate overall cost of concrete system
    - iii. Compare cost of existing steel system to redesigned concrete system
  - b. Schedule analysis
    - i. Adjust existing construction schedule to account for concrete system
    - ii. Compare construction time of existing steel system to redesigned concrete system and determine impact of the critical path.
  - c. Determine feasibility of concrete system.



#### 4. Perform check/design of drainage system

- a. Research current drainage system and drainage pipe location
- b. Research waterproofing systems
- c. Specify waterproofing for the foundation wall and the basement slab
- d. Size the drainage pipe
  - i. Determine location of the water table
  - ii. Determine flow rate of water
  - iii. Size drainage pipe and sump pump (if required) using geotechnical engineer's recommendations and industry standards
  - iv. Specify drainage system outlet

#### 5. Final Report and Presentation

- a. Outline final report
- b. Write and format final report
- c. Outline presentation
- d. Create presentation slide show
- e. Finalize report
- f. Practice presentation

# Schedule



Proposed Thesis Semester Schedule																						
January 2014 - May 2014																						
13-Jan-14	20-Jan-14	27-Jan-14	3-Feb-14	10-Feb-14	17-Feb-14	24-Feb-14	3-Mar-14	10-Mar-14	17-Mar-14	24-Mar-14	31-Mar-14	7-Apr-14	14-Apr-14	21-Apr-14	28-Apr-14	5-May-14						
Design Floor System and Columns								Spring Break				Final Report: April 9	Faculty Jury Presentation: April 14-18	ABET Assessment	Senior Banquet May 2	Finals Week						
	Use RAM Concept to Check Gravity System																					
		Use SP Column to Check Columns																				
			Verify RAM Concept Output																			
			Investigate Post-Tensioned System																			
			Perform Design and Analysis of Drainage System																			
						Perform Detailed Estimate of Reinforced Concrete System																
										Perform Schedule Analysis												
										Compare cost and schedule of concrete system with original system												
									Check Lateral System													
										Write and Finalize Final Report												
										Organize File Presentation												
													Update CPEP and Report									

## Conclusion

The structural system for the New Library at the University of Virginia's College at Wise was adequately designed for strength and serviceability requirements. As a result, a scenario has been proposed in which the University would like to investigate the option of a concrete system. The University would also like to investigate the option of a post-tensioned system.

The building's structural system will be redesigned using a mild-steel reinforced concrete flat slab with drop panels. This system is the least expensive of the alternative concrete systems considered in Technical Report 3, is an industry standard, and is ideal for the bay sizes commonly found in the New Library. To address excessive floor deflections, which will be a concern in the larger bays, camber and alternative drop panel sizes will be investigated. There is also an interest to investigate the option of a post-tensioned system as a secondary redesign, so a schematic design of a portion of the floor system will be completed and compared to the two-way slab system. Both systems will be designed using RAM Concept.

The existing lateral system will be integrated with the concrete floor system. Due to time constraints on the proposed work, and the interest to focus largely on the design and analysis of the concrete floor systems, the analysis of the lateral system will be limited to member checks under the increased shear forces and consideration of the effects the foundation walls on the torsion and drift of the structure. A more in depth study of the lateral system will be completed if time allows.

Concrete columns will be designed using the existing layout. This will minimize the impact of the system redesign on the building's interior layout.

Changing the structure to a concrete system will result in a difference in cost and construction time for the project. To determine how the concrete system will compare with the existing steel system, a detailed cost estimate of the concrete system will be compared to that of the existing system. Impacts on the construction schedule will also be investigated. This comparison will help determine the feasibility of designing the structural system in concrete.

Due to the large depth of the foundation walls, drainage at the base of the walls is a concern. Therefore, the drainage system at the base of the foundation walls will be designed to adequately prevent water buildup at the base of the walls. An investigation of waterproofing for the foundation walls and the basement slab will also be completed.

MAE coursework will be incorporated into the redesign through the use of computer modeling of both the gravity and lateral systems, including a guided self-study of RAM Concept for the modeling of both conventionally reinforced two-way concrete slabs and post-tensioned concrete slabs.